

Plasticity Modeling

F6

Preliminary Report

Omar Almutairi

Nawaf Alkhalaf

Mutairan Alhabashi

Abdullah Almutairi

2017-2018

**NORTHERN
ARIZONA
UNIVERSITY®**



Project Sponsor: ME department

Faculty Advisor: Dr. Heidi Feigenbaum

Instructor: Dr. Sarah Oman

DISCLAIMER

This report was prepared by students as part of a university course requirement. While considerable effort has been put into the project, it is not the work of licensed engineers and has not undergone the extensive verification that is common in the profession. The information, data, conclusions, and content of this report should not be relied on or utilized without thorough, independent testing and verification. University faculty members may have been associated with this project as advisors, sponsors, or course instructors, but as such they are not responsible for the accuracy of results or conclusions.

EXECUTIVE SUMMARY

The purpose of this report is to design an experimental device used by Dr. Feigenbaum, that will help visualize the elasticity theory. The device will measure the force applied to a plastic box that works in both tension and compression. It will also measure the displacement of the box on a frictional surface. The device will be connected to a computer and will use the capstone software to display force vs. displacement for both x and y direction. A force gauge and possibly a spring gauge will be used to give an accurate reading of the force applied. An Arduino Uno board will be used as the heart of the sensors that are attached to the box, it will measure the displacement. The overall design will be module, where springs can be added or removed by the user. The box itself should be heavy enough to stretch the springs before it starts to move. This project will be used by Dr. Feigenbaum's graduate level students and hopefully be used by universities across the country.

Table of Contents

DISCLAIMER	2
EXECUTIVE SUMMARY	3
1. BACKGROUND	5
1.1 Introduction	6
1.2 Project Description	6
1.3 Original System	6
1.3.1 Original System Structure	7
1.3.2 Original System Operation	7
1.3.3 Original System Performance	7
2. REQUIREMENTS	7
2.1 Customer Requirements	8
2.2 Engineering Requirements	9
2.3 Testing Procedures	10
2.3.1 Spring Expansions	10
2.3.2 Elasticity	10
2.3.3 Pushing and Pulling Force	10
2.3.4 Frictional factor	10
2.3.5 Weight of a system	10
2.3.6 Length of Sliding Area	11
2.3.7 Sliding Box weight	11
2.3.8 X Y Direction Displacement	11
2.3.9 Durability	11
2.3.10 Reliability	11
2.4 House of Quality	11
3. EXISTING DESIGNS	12
3.1 Design Research	12
3.2 System Level	13
3.2.1 Existing Design #1: Elastic	13
3.2.2 Existing Design #2: Linear	14
3.2.3 Existing Design #3: Springs	14
3.3 Functional Decomposition	14
3.3.1 Black Box Model	15
3.3.2 Functional Model/Work-Process Diagram/Hierarchical Task Analysis	16

3.4 Subsystem Level	16
3.4.1 Subsystem #1: Arduino codes set up	17
3.4.1.1 Existing Design #1: Arduino programming	17
3.4.1.2 Existing Design #2: Sensors	17
3.4.1.3 Existing Design #3: Kinematic equations	18
3.4.2 Subsystem #2: How does it Not Fall	19
3.4.2.1 Existing Design #1: Safety	19
3.4.2.2 Existing Design #2: Easy to carry	19
3.4.2.3 Existing Design #3: Shape	19
3.4.3 Subsystem #3: Microcontroller	20
3.4.3.1 Existing Design #1: Code	20
3.4.3.2 Existing Design #2: Flat Circuit	20
3.4.3.3 Existing Design #3: Board	20
4. DESIGNS CONSIDERED	20
4.1 Design # 1: Simple Basic Module	21
4.2 Design # 2: Force Gauge screen with simple module	22
4.3 Design # 3: Force and Spring Gauge with simple module	23
4.4 Design # 4: Box sliding over frictional surface	24
4.5 Design # 5: Box attached with a spring all connected to a rigid wall	25
4.6 Design # 6: Box connected with a spring & the rigid body is connected on the z plane	26
5. Design Selected	26
5.1 Rationale for Design Selection	27
5.2 Design Description	29
6 PROPOSED DESIGN	30
6.1 Bill Of Materials	30
6.2 Gantt Chart	30
6.3 Cost and Budget	31
7. REFERENCES	32
8. Appendices	34
8.1: Appendix A: House of Quality	34
8.2 Appendix B: BOM	35
8.3 Appendix C: Gantt Chart for the Second Semester.	37

1. BACKGROUND

This section will be an introduction to our project. Which is basically a block box that slides over a frictional surface along X & Y directions, when the student applied force on it they should get an F vs displacement graph with F direction. Also we will be discussing the project description, original system and structure. We will be working through the entire report explaining each parts, for example, the original system structure. Last but not least, there are couple of equations we are going to use especially with the kinematic equations as we need to get a F (u, v) vs displacement graph at the end of the system process. In this chapter, we are going through the design aspects by discussing the system operation, performance, operation and etc...

1.1 INTRODUCTION

In this capstone course, we are challenged to work with a non-profit local project. It's basically a plastic box model that moves in both x & y directions. The design should be able to demonstrate the elasticity theory for students. This project will be used as an educational tool for Dr. Feigenbaum's advanced classes for plasticity. So our design should be creative with the idea and easy to deal with for all students. In order to deliver for the students the elasticity theory, we will attach the sliding box with a spring and whenever the student apply a tension or compression on the spring it will immediately graph an output for force vs displacement on both x & y directions. Now student should be able to clearly understand how the elastic limit behave. This project will benefits both the sponsor which is Dr. Feigenbaum and students who studying the plasticity classes as well as the mechanical engineering department they are our primary stakeholders. The major obstacle we could face in this project is how to connect the sliding box to a device to display for us the graphs we need.

1.2 PROJECT DESCRIPTION

This is an educational local project that helps both Dr. Feigenbaum and her graduate level students who are taking plasticity classes. We are going to build a box on different surfaces and attach that box with a free springs and other springs are connected to a fixed frame to explain for the students the behaviors of the elasticity theory. The design should be a desktop sized, small enough to be stored in her office, and seen in the classroom of 20 students as well as easy to carry without extra help. The physical model will be controlled by the student when applying tension (pull) or compression (push) on the spring. After that, the student should get an immediate output graphs for the forces vs displacement in both X & Y directions.

1.3 ORIGINAL SYSTEM

Purpose of this project is to build a tabletop model in order to find the plastic and elastic-plastic materials behavior. As the project requirement is to build such system so basically it is an Original system. The project involved the design of a completely new elastic behavior model using the sliding box and spring system. There was no original system when this project began.

Dr. Feigenbaum will use this device to explain how the material behaves after the elastic limit. In this model a spring will connect to the box from one free end and the other end of spring connects with the fixed support. The box is connected to a spring, is on frictional surface, where the box has resistance when sliding over the surface. Surface has some sort of friction and slider box can slide over it easily with the help of spring to move to and fro over it. In order to understand the behavior of material after the elasticity then multiple frictional surfaces will use to test, and multiple size of boxes will use and multiple type of material will use for the box. There will multiple type of springs will use with different stiffness in the spring. Through this project we will determine the deformation caused by the force and see how much deformation appeared. So force vs. displacements will measure for it.

1.3.1 ORIGINAL SYSTEM STRUCTURE

As it has mentioned earlier that the project we are going to build in this semester hasn't been built before and we have searched similar project over the internet but nothing has found similar to our project that's why this project is totally original system and we are not improving any other system. Similar model have built before but those models are not for doing the elasticity measures and behaviors. Such models are just based for spring motions and this model will review the behavior of materials after reaching to their elasticity. So the structure of our model is that there will be a fixed end of a spring and an open end, with the open end connects to the sliding box over the surface. The surface has some friction as well so this is how our model will built.

1.3.2 ORIGINAL SYSTEM OPERATION

There is no other original system then the one we are building in this project so there is no operation for any other system available. And to explain the operation of our project it will see the displacement cover when the force will apply. The displacement will cover in 2D one is x-axis and second is y-axis. So the operation is that the box will slide through a force and it will cover a distance because of sliding and friction will hold the box until the spring will deform.

$$F = F_x i + F_y j \text{ ----- (1)}$$

$$u = u_x i + u_y j \text{ ----- (2)}$$

With the above equations we will do the plots. So the graphs that will make at the end of this operation will be for force vs. displacement in both x direction and y direction.

1.3.3 ORIGINAL SYSTEM PERFORMANCE

There is no original system so we cannot find any performance for any original system. The original system is the one we are building so we cannot mention any original system performance unless our system will build. Furthermore our system being the original system will do the analysis on the behavior of plastic materials elasticity.

1.3.4 Original System Deficiencies

For our project, we had to come up with an original idea that satisfies the client's requirements. It was hard to know what the deficiencies are in the system, since there is no original system. All we know, is that the hard part and the most important one is to generate a graph, and we need to make sure that they are no deficiencies including that part.

2. REQUIREMENTS

The design that we are going to build is basically going to be used by student who are taking the advanced classes for plasticity with Dr. Feigenbaum. This section will include the customer requirements, engineering requirements, testing procedures and house of quality. Couple of the requirements are difficult because we must give our client the best design that will be good to provide for her students. She wanted a design that grab the attention for her students in the classroom.

2.1 CUSTOMER REQUIREMENTS

The team generated Table 1.1 after meeting with the client, where she talked about the overall function and the constraints of the device. She made it clear that she wanted the device to be visible to a whole classroom, but also lightweight and easy to carry. The table below summarizes the requirements and the description of each one.

Customer Requirements	Description
Desktop sized system	It means a small to medium design device. Basically it's going to be around the standard size table.
Large to seen in the classroom of 20 students	Design with a good shape, so that all the students in the class can see how is the design work.
Small to store in an office	Good size that is not large or heavy so she can hold it with other help and can fit directly to the client's office.
System will control by user	A force exerted by the student and that force will be the out
System must work in both tension and compression	There must be connection
User can change the direction of force at any point during loading	By the frictional force
Tabletop model Plotting force vs. displacement	A design that is good to be a size of a table.
Multiple frictional surfaces	Means by multiple users

Table 1.1: Customer Requirements

2.2 ENGINEERING REQUIREMENTS

From the customer requirements, the team generated a list of engineering requirements that will

satisfy the client's needs. These requirements focuses on the actual components of system and their targeted values. These values will help in building the project because there will be our targeted values and while selecting the design, implementation the design ideas, these targeted values will kept in mind so it will be easy to develop different ideas and it will easy to select the final design on the basis of these requirements and targeted values. Engineering Requirements for the project is listed below in Table 1.2.

Engineering Requirements	Targeted values or Tolerance
Spring Expansions	0.3 m
Elasticity	1 m
Pushing Pulling Force	10 N
Frictional Factors	1
Weight of system	18 Kg
Length of Sliding Area	1 m
Wireless Control distance	5 m
Weight of Sliding Box	2 Kg
X Y direction displacement	0.762 m in the X 0.508 m in the Y
Durability	5 years
Reliability	90% success rate.

Table 1.2: Engineering Requirements

We didn't find any difficulties with the cost of our project. We will be using materials that are easy to use and also will be valuable for graduate level classes. Our client is looking for a design that is easy to use and also light. That she can hold it with here everywhere. Most of the targets were given to the team from the client. The design of our device limit the displacements in both directions to the values you see in table 1.2.

2.3 TESTING PROCEDURES

As the engineering requirements have defined so it becomes necessary to test the engineering requirements before proceeding for the further design analysis because if the engineering targeting values are wrong or not achieving or crossing the limit then we must change these values before moving on. Therefore different sort of testing procedures will apply for different requirements. And these testing procedures have mentioned below. The most important testing part, is generating accurate graphs where we will measure the displacement using a regular ruler and comparing it to the values that we got from the Arduino to generate the graphs needed. In this section we will go over the most important testing procedures for the design.

2.3.1 SPRING EXPANSIONS

Testing of spring expansion can be done by hand by simply expanding it and compressing it by placing a scale by the side of it and determine how much it is expanding and how much it is compressing. If the compression is long or expansion is long then we need to change the targeted values. The spring is expected to deform at some point during the lifetime of the device, and will have to be replaced by the client if needed. The team will use an adjustable "removable" springs and that will make the process of changing the spring position anytime is easy and that will absolutely will met the engineering requirement as they need a distance to move freely with the spring and can change it's position at anytime.

2.3.2 ELASTICITY

The main idea of this project remain in this section of the testing procedures. Because we basically want the students who are using the design will be able to understand how the elasticity of the materials will behave and that's why the elasticity should be included in our testing procedures. Since we have the process of pulling or pushing we did met the engineering requirements and explained what does the elasticity mean. The Elasticity of the material can also determine in the same way by making a holder of same material so that it can hold and stretch through two hands or there is a machine available for stretching so place the material inside that machine and determine its elasticity. Elasticity of any standard material is available online as well in order to verify.

2.3.3 PUSHING AND PULLING FORCE

Pushing and pulling force can determine through a force detection sensor. This sensor can determine a force apply by a human being. So a person who will push and pull the box in this project will apply the force on this machine and will determine whether the force mentioned is correct or need to make some changes in it. As we are going to use a force gauge to test the system. We will figure out how much is the required or the appropriate force to be added in there

and not let the system failed. We have to kind of forces in this design. First, it's the human force (push or pull) that will exerted on the system. The other force will be

$$F = -KX \text{-----} (3)$$

From Eq. 3 it's a Hooke's law and that what we get for the second force when the spring pulling the box towards the wall. That make sense because we have negative sign multiply by the spring constant.

2.3.4 SURFACE FACTOR

Surface factor can determine by the friction factor and friction of any material is used. We used carpet in the surface of our design so we could get the result that we are expecting. the friction value can be collected online. Applying the formula to calculate the frictional force. Will help us in getting the exact results. The surface factor meet our engineering requirements such as adding carpet will make it easy to use. Since we have push and pull surface. When the student pull the design with the springs on the other side the force will help us to pull on the reverse side. In this case we will have higher surface factor force.

2.3.5 WEIGHT OF A SYSTEM

The overall weight of a system is what we added to our design to make it easy to hold. We added light wood to the surface of the design which made our design more light weight and more accurate. The result that will be collected is from the user because he will be able to hold it. The weight of a surface meet the engineering requirement by getting the wood and adding it to the surface that made a huge difference in our design. We estimate that our design will be around 5 kg. That the client will be able to hold it with one hand and it doesn't fall easily as well as a safety handle.

2.3.6 LENGTH OF SLIDING AREA

The sliding area length is standard size and it can check through any slider that is satisfied. Increasing the sliding area could result in increasing the total weight of the system, which we are limited to around 40lbs. We used light material so the frictional force can move easily over the system. The dimensions of the whole device is easy to collect and the materials that are used meet our client satisfaction and engineering requirement. In case of safety and sliding friction force. Our team is thinking to make around that is 1.5m distance between the box and the wall. So when the user use the springs to push the box . He or she will get a good result for the sliding box.

2.3.7 SENSORS

We used two kinds of sensors. Speed sensors and pressure sensors. The speed sensor is BMP180 which helped us in calculating the surface speed. Pressure sensors helped us in calculating the distance from the point of pushing to the point of pulling. Adding force gage will help us to have an accurate reading of the force that been applied to the system. Our sensor meet our engineering requirements in the case of adding it to the arduino. The pressure sensor will go right after the box and will be attached in the spring as well. However the speed sensor will be attached between the output springs and the box to measure the user speed when moving the box and then apply it all to the kinematic equation to figure out the acceleration needed to calculate the distance. The pressure sensor will be there to enhance our results.

2.3.8 X Y DIRECTION DISPLACEMENT

This is the displacement measure, and it just need to check by moving the box over the scale that it is giving the correct value or not. The box will only be moving along the x and y-axes, where we will be also testing how free it's moving. The box should not be affected by any resistance that are not either the frictional surface or by the springs. Basically,

F_u is the output force that we will get when we move along x – direction . However, the F_v is the output force that we will get when we move along y – direction.

2.3.9 ARDUINO-UNO

This device will play a big role in our design since it's considered the main electrical part and all the connection will be through the Arduino board. We will be connecting all the wires with the sensors and the Arduino Then we will program it through the Arduino program using some IF commands to have the codes for force VS displacement. Then we should have our results for the graphs and the force gauge also will be connected with the Arduino to gave us an accurate reading for forces applied by the user to the system design. This part is very important in term of met the engineering requirements. As students want to see a good nice curve for *Forces(u, v) vs. displacement* . At the end, We need to program all the codes we have from the Arduino and connect it to the Excel to display the graphs.

2.3.10 RELIABILITY

Our team decide to use reliability items in our design. We used lightweight materials such as wood and springs. Our result will be collecting throw the arduino connected from our design to the laptop and The higher the accuracy of the readings, the more reliable the device is . Then the user will find the results showed by a graph and by measuring the actual displacement by a ruler and comparing it to the readings on the computer screen. The customer requirements meet the engineering requirements such as safety. After we searched about our design and asked about 80 % of people they suggest to use a light wood as well as a strong frictional surface to make it more reliability and durability.

2.4 HOUSE OF QUALITY

Quality, which in this case refers to meeting the needs of our client. The House of Quality (HoQ) basically show the correlation between the customer and engineering requirements. The customer requirements comes directly from Dr. Feigenbaum, as she insisted on making the system easy to carry and store in an office. We came up with the engineering requirements that helped meet the customer needs, where we specified the size and weight of the system. The below caption will give a brief description of the first few customer requirements with the engineering requirements related to it and the completed HoQ will be on the Appendix A.

Customer Requirement	Weight	Engineering Requirement	Compat Design	Weight of system	Frictional Factor	Motion/Force sensor
1. Easy to be stored in an office	10		9	3		
2. Visible from a distance	4		1			
3. Desktop sized	8		9	3		
4. Various types of spring	1					
5. Portable	9		3	9		
6. Easy to carry	6		3	9		
7. Generate different types of graphs	7					9

Figure 1: Caption taken from the HoQ in appendix A

3. EXISTING DESIGNS

Our existing design is to build a sliding box that works in both X & Y axis. That box should be attached in 2 springs on a frictional surface. As one spring will be used to pulls or pushes when a student apply a force on it. The other spring will be connected between the sliding box and a rigid wall. The student will get an immediate plot for force versus displacement depend on the axis that he/she applied the force on. The design will be unique and creative so it can deliver for the student how the elasticity behave. So in this chapter will go over the system & subsystem design and as the design will be used as an educated tool for the students we will consider it from the STEM that involves all science, technology, engineering, and math.

3.1 DESIGN RESEARCH

Several researches have been made for the plasticity modeling and finally we have come up with UCAR as well as Mechanical department to be our benchmarking. This design will be explained for student that taking Dr. Feigenbaum advanced classes in plasticity. This design will be doing

from scratch as we don't have any previous designs made for plasticity. When we look over the UCAR cite we saw different design made as a teaching box for the student in the classroom, and we saw how well they understand when using those teaching box. "UCAR Center for Science Education Teaching Boxes are themed collections of classroom-ready educational resources to build student understanding of science, technology, engineering, and math (STEM). Resources highlighted within teaching boxes are developed from UCAR Center for Science Education and other credible education programs, and have been vetted by the Center's education team." [1]. We are not going to really find any issues, because all the designs was helpful to give us a good start with our sliding box design and as long as they are under STEM they helped us with the idea is how to make the students be an interactive with teaching box. This benchmark which is the UCAR was benefits with giving us a good ideas of the teaching box and how to be a great with a design so the student will be interactively with it and understand the process going on right away.

3.2 SYSTEM LEVEL

In the current project the major objective is to focus on plasticity modeling by looking at its significance. Linear elasticity model is very crucial especially to modeling materials which undergo small deformations and which return to their original configuration when the load is removed. This illustration is shown by use of springs on a block placed o a table. When the spring is pulled by the user it stretches until its elastic limit is reached. When there is a lot of friction the spring stretches more as opposed to when the friction is less. In this regard, during the real applications of plasticity an allowance should be given in case of extreme cases of friction i.e. a lot of friction or less friction. This means that during building and construction and manufacturing of various products their tensile strength should be considered so as to avoid occurrence of accidents.

The current model has a wide range of applications as discussed below. In the building and construction industry concrete is a very crucial component and is a mixture of sand, ballast and cement. The right mixing ensures that the concrete is able to withstand heavy loads. On the other hand, gaps are normally left in between large portions of concrete so as to avoid cracking of concrete when the temperatures are high or when it is subjected to extremely heavy load. Another application of plasticity is in the spring balance which is used to measure weights. When a load is attached to a spring balance, the spring stretches up to a certain limit so that the correct weight can be read from the calibrations. In case a very heavy load is hanged on the spring balance the spring will stretch until its elastic limit is reached. The spring results into an irreversible deformation.

3.2.1 EXISTING DESIGN #1: ELASTIC

This entails an ideally elastic perfectly plastic model whereby a spring is fixed on a block and then pulled along a surface. The spring stretches as the block resist moving. Once the spring is fully stretched the movement becomes constant. This model is significant and it is one of the most successful plasticity models. In this model requires a single experimental input is required i.e. The yield strength. Flows under various boundary conditions are analyzed. It is mostly used

in the analysis of the processes involved in the formation of metals and the carrying of loads. In addition, the model can also be used in the description of the yield stress fluids like greases and toothpastes. However, this model can mostly be applied in light objects which do not require a lot of strength to make them move [2].



Figure 2: figure that shows the yield strength [2]

3.2.2 EXISTING DESIGN #2: LINEAR

This design entails rigid linear hardening whereby a spring is attached to a fixed point and one end is attached to the block. In this case, when the force is applied to move the block, movement is constant as the spring stretches uniformly. In this case, when the stress is below the first yield strength, the material is inflexible, and this makes the stress to increase along a vertical line, $\gamma = 0$. In this case elastic deformation is neglected. When the stress is increased again and often goes beyond the initial yield strength, then the material starts to move. When the stress-strain curve monotonically increases, then the material is regarded to have strain-hardened. The idea behind this model is to reduce friction on the surface on which the block is moving so as to facilitate movement. Also, a limited amount of force is applied by the user [3].

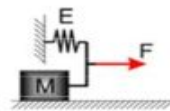

Figure 3: Shows the strength [3]

3.2.3 EXISTING DESIGN #3: SPRINGS

This design entails elastic linear work hardening which entails use of two springs whereby one is attached to the block while the other one is fixed. On pulling the result is that the stretching is constant until the elastic limit is reached.

When two springs are used the strain is distributed equally between the two springs and hence the springs do not undergo complete deformations. Also, there is a lot of strength as a result of the

two springs. However, this strengthening occurs as a result of dislocation movements and dislocation generation within the two springs. This method is normally applicable in materials which have a high rate of hardening. In this regard, the two springs do not undergo maximum deformation since before the elastic limit is reached movement would have occurred. Therefore this method can perfectly fit movement of relatively heavy blocks [3].

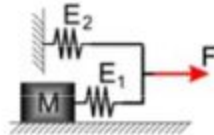

Figure 4: is the design elastic work [3]

3.3 FUNCTIONAL DECOMPOSITION

Below we breakdown the main parts for our project and we came up with the following block box that should be weightless and attached with 2 springs, we are going to use 2 springs, one will be connected between the rigid wall and the box that cause deformation, however the other spring will be used to pull or push on the spring. The main work will be on the X and Y axis as the client don't want us to use the Z axis. The frictional surface whether be high or low. Lastly, we are going to use 2 kind of sensor one to measure the distance between the block and the rigid wall, other to measure the speed for the user.

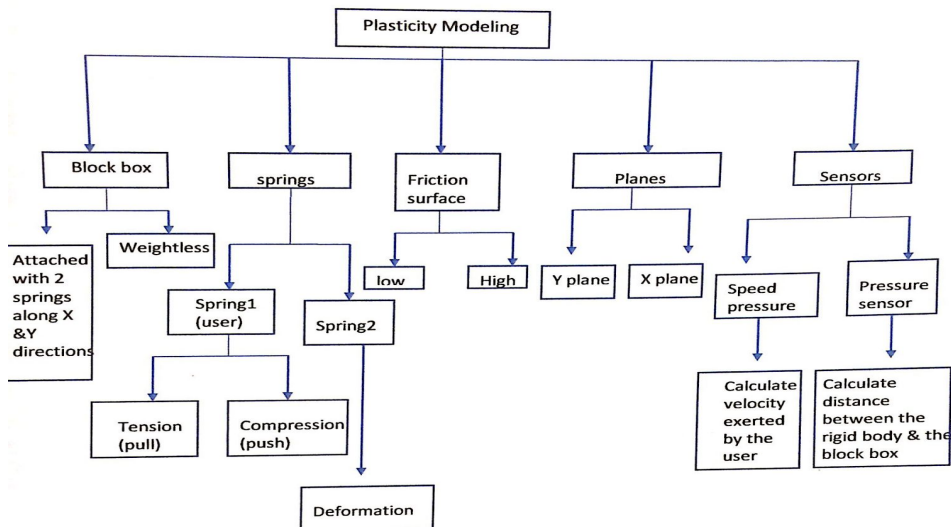

Figure 5: Functional decomposition for our design.

3.3.1 BLACK BOX MODEL

The Black Box Model simplifies the functionality of the system and also lays out its inputs and outputs. For our case, the main function is to generate graphs of forces acting on the system, where we input a force which caused displacement which eventually plot a graph as an output. Below in Figure 6, is the Black Box Model.

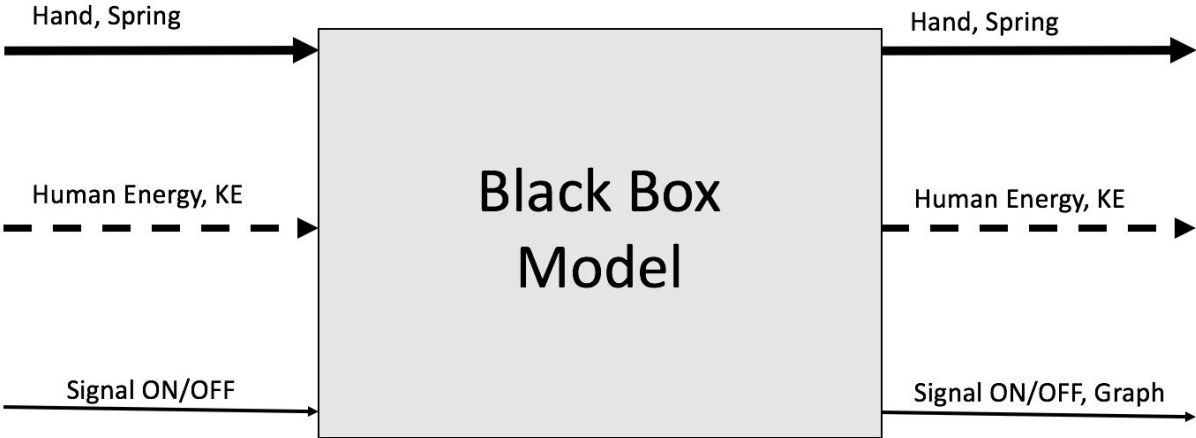

Figure 6: Black Box Model

3.3.2 FUNCTIONAL MODEL/WORK-PROCESS DIAGRAM/HIERARCHICAL TASK ANALYSIS

This functional model is breakdown in a way that clearly shows how the design is being work and in each step it shows what is the energy used. This will definitely give a team a clear idea of how the system should work. As we start with sliding the box and give the spring tension or compression we are exerting a mechanical energy, when the friction happens that will led to a thermal energy, the sensor will translate all the codes into Arduino and then it will plot the graph and that will be the electrical engineering.

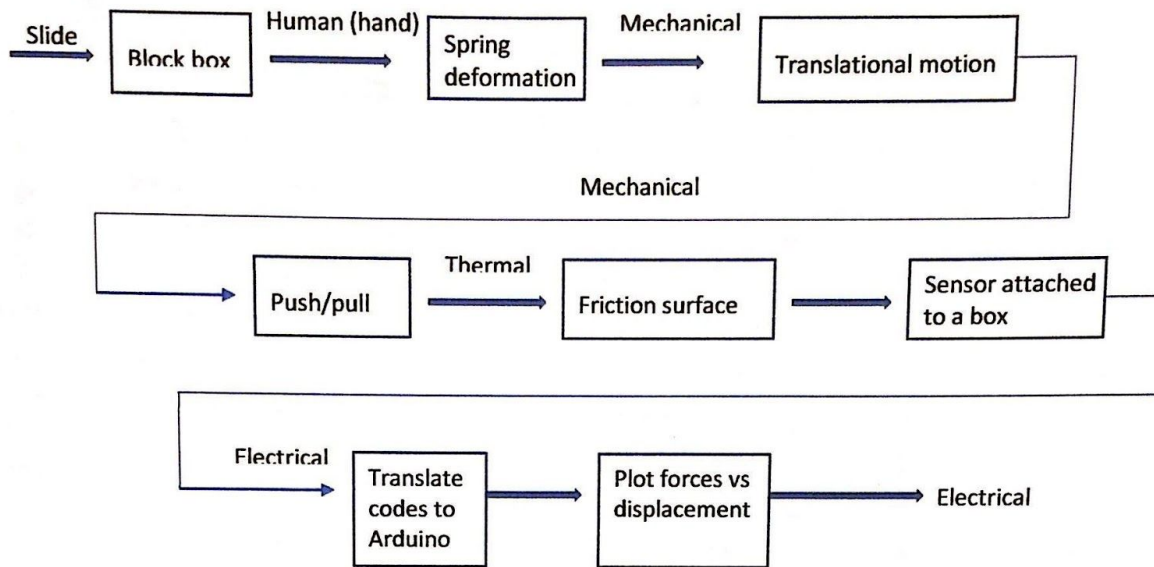

Figure 7: Functional Model

3.4 SUBSYSTEM LEVEL

The subsystem level is important in our project. Without those components we couldn't build our design. Around ten system level we are going to use to create the plasticity design. Our client gave us couple of things that she is looking on the final design such as Arduino, microcontroller, springs and etc. Output data is the data that will be used to create the device that our client wants. For example the row data input coding is the data that it inputs the codes that we will be doing on the MATLAB. Applying Arduino codes set up is the connection between the device and the codes we set up the final input. Also, microcontroller will be used to activate the codes of the device. The force system will be calculated after we got the final testing.

The table top display shows the final numbers and forces that we calculated on the design. The system will include suction cups below the surface to keep it from moving/falling when force is applied. Displaying outputs is the final shape of the device that we will be creating. Force gauge is the force that we will be used to move the design from one side to the other without any damages. Spring deformation gauges are the springs that will be used to activate the device and making the force move and help to define the spring constant.

3.4.1 SUBSYSTEM #1: ARDUINO CODES SET UP

In this design, we are going to use the Arduino connected with the 2 sensors to translate all the codes we are running to plot the F_x vs u , and F_y vs v . so we need to go over all the kinematic equations and figure out how to set them up using the Arduino program. Then we need to do the connection between the sensors and the Arduino and apply it to excel for the plot.

3.4.1.1 EXISTING DESIGN #1: ARDUINO PROGRAMMING

It would be all about if the user pulls or push the spring whether it in the X or Y axis it should do all the calculations and at the end of the process should plot a graph of the force versus displacement. The time will be calculated using a stopwatch and then will be apply it over the displacement to get the velocity then apply to get the acceleration. At the end we will be able to get the force. By using this device, it will help us to get the graph we need right away.



Figure 8: Arduino Uno [4]

3.4.1.2 EXISTING DESIGN #2: SENSORS

For our design we are going to use 2 kind of sensor. We will program (BMP180) sensor which is the pressure sensor to calculate the distance between the block and the rigid wall as the time been calculated using a stopwatch. Furthermore, the other sensor we will be used to calculate the speed for the user as moves. This kind of sensor is (LM393) that can give us a perfect approximate for the user speed.

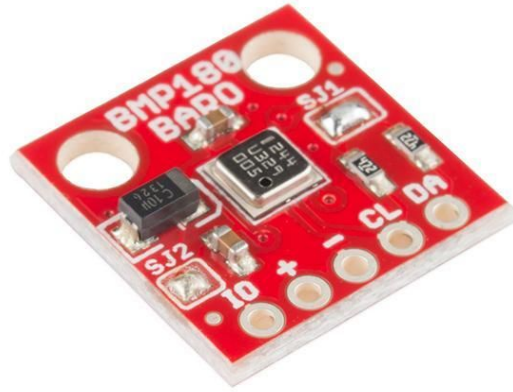

Figure 9: The below figure will show a full connection of how to setup the speed sensor with the Arduino [5]

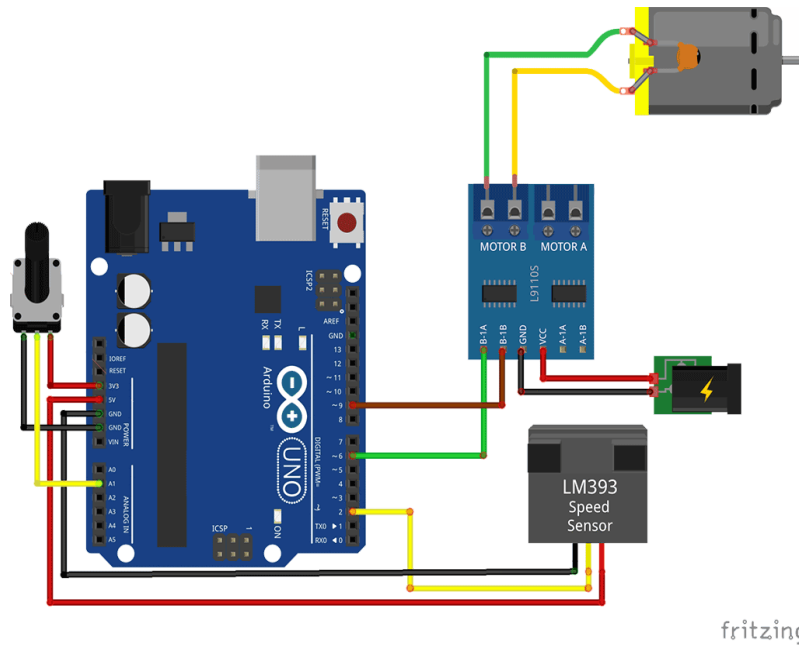

Figure 10: Shows the connection between the LM393 & Arduino [6]

3.4.1.3 EXISTING DESIGN #3: KINEMATIC EQUATIONS

Those are the equations to be applied using the Arduino program. As long as we calculate the acceleration we can find the force. By using the kinematic equations with the speed sensor we can figure out the displacement.

We define the force as $F = m * a$

Velocity equation $V = \frac{\Delta m}{t}$

Acceleration equation $a = \frac{\Delta v}{t}$

Here are the kinematic equations to solve for the displacement:

$$d = v_i * t + \frac{1}{2} * a * (t)^2 \text{-----} (4)$$

$$(v_f)^2 = (v_i)^2 + 2 * a * d \text{-----} (5)$$

$$v_f = v_i + a * (t) \text{-----} (6)$$

3.4.2 SUBSYSTEM #2: HOW DOES IT NOT FALL

The subsystem is important to our project because it's a device and it must not fall. As our client and our department sponsored they indicated that they don't want something easy to fall.

They wanted a design that can be provided for a graduated level senior's class.

3.4.2.1 EXISTING DESIGN #1: SAFETY

We are required to create a design that is secure and safe for the customers. A design that our client can hold it and walk through anywhere. The safety requirements are creating a design with useful products that can help the customer not to get hurt.

3.4.2.2 EXISTING DESIGN #2: EASY TO CARRY

The design of the system must not exceed 18 Kg in weight. Our client is looking for a smaller shape that is easy to carry. The box itself must be at least 2 kg, so it has some sort of gravitational resistance when force applied from the client/students.

3.4.2.3 EXISTING DESIGN #3: SHAPE

The shape of the design must be meaningful for example a design that will grab the customer attention with colors. The shape must be easy to see and hold a medium size shape. It should have hooks all around, where students can add/remove springs on demand, which makes it module. The system should also be a tabletop design, which can easily be stored away.

3.4.3 SUBSYSTEM #3: MICROCONTROLLER

The microcontroller will be used in our design so we can build the device that our client wants. It will be embedded to the sensor and the Arduino which will complete the setup of the system. It is cheap but also significant to the success of our project eventually.

3.4.3.1 EXISTING DESIGN #1: CODE

The code will be applied on the flat surface of the microcontroller. Since it will be connecting to the Arduino that will help getting the codes through the MATLAB program. The team must write a code that will plot a graph of the force applied by the user versus the displacement of the box. A code also be written to display the graph on a screen or a connected computer.

3.4.3.2 EXISTING DESIGN #2: FLAT CIRCUIT

The flat circuit is one of the important things in the microcontroller for example it will help to get the exact data of our design. It will be calculated when we create our design. It relates to our requirements because we need to build a design that can be used to multiple users. Eventually, it helps with the data precision and accuracy of the readings.

3.4.3.3 EXISTING DESIGN #3: BOARD

Board is the first step in creating a microcontroller. It adds all of the other requirement for the project for example sensor, shape and the battery. It's basically where the electrical components are attached and stored away from the user. Any damage to this board can cause the whole system to fail, so this needs to be covered from dust and liquids. Below in Figure 12, is an example of what a board looks like.

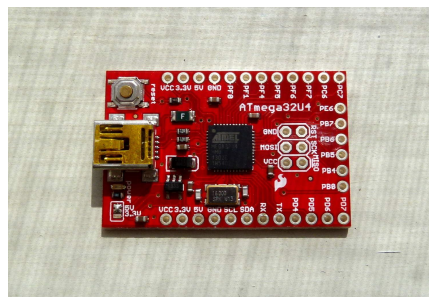

Figure 12: The figure shows the board of the microcontroller that will be used.[7]

4. DESIGNS CONSIDERED

In this chapter of the report, we will discuss the designs that the client suggested and also designs that the team considered. There will be a list of advantages and disadvantages of each design that will help us narrow down the options and eventually choose our final design to go forward with. Below you will find figures and diagrams that will help you visualize the system as a whole.

4.1 DESIGN # 1: SIMPLE BASIC MODULE

This is the first design idea in which we have placed two springs one is fixed one from both sides and the second spring is open from one end. In this way the box will move with the help of spring by stretching the spring. And the displacement covers by the box will record in the system through the help of Arduino controllers. And then the controller and system will generate the graph of force vs. displacement. Here is the module showing below in the figure 13.

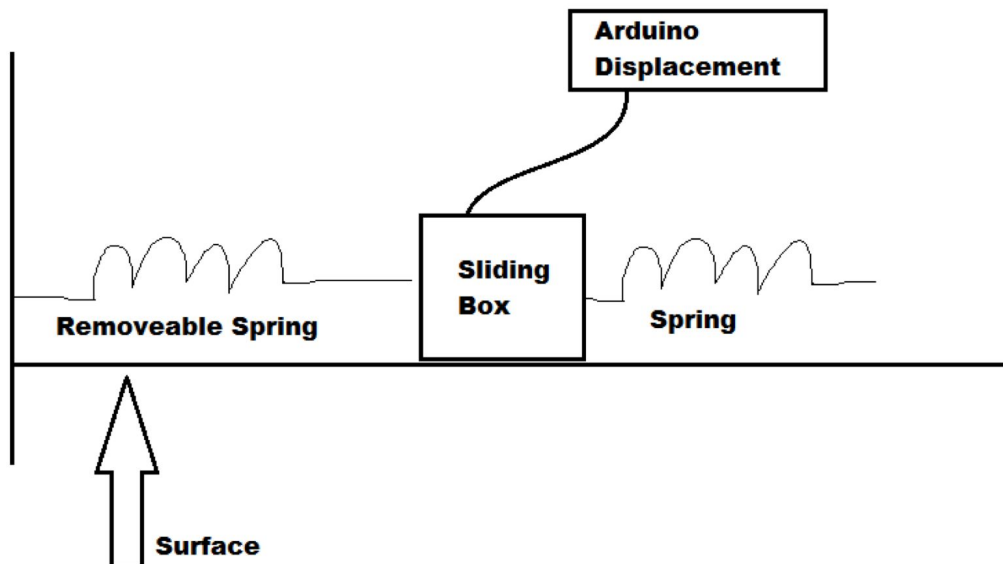

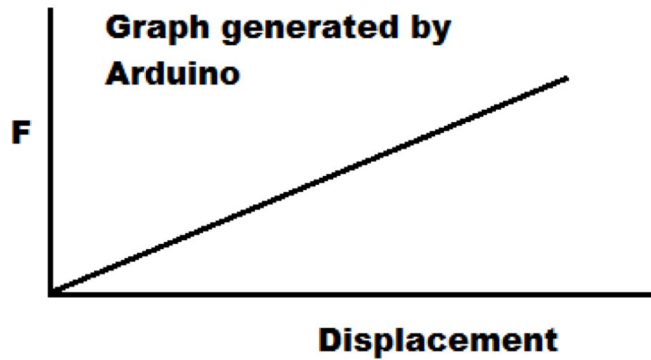

Figure 13: Basic Module

Advantages

Following are the advantages

1. Removable spring can make it easy to adjust and slide over the surface.
2. Spring elasticity will not affect material elasticity.

Disadvantages

Following are the disadvantages

1. For drawing force vs. displacement curve we need an extra computer screen to draw and show the curve.
2. Processing will be slow because of extra screen attach to it.
3. It will be difficult to make it portable

4.2 DESIGN # 2: FORCE GAUGE SCREEN WITH SIMPLE MODULE

This is a design amended from the previous design and in this design we will put a force gauge in the system, so that force will determine through the screen continually. And remaining removable springs have attached as well which can remove at any instance. This design is showing below in the figure 14.

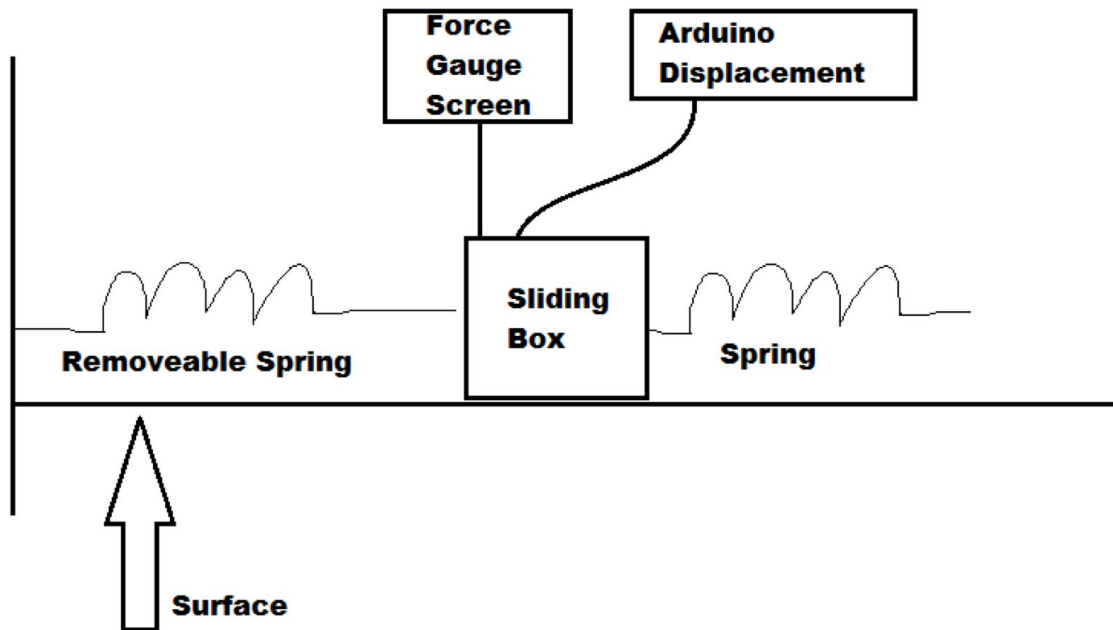

Figure 14: Simple Module with Force Gauge

Advantages

Following are the advantages for this design system

1. Force curve is available so force will monitor continually and it can vary eventually
2. Removable spring can make it easy to adjust and slide over the surface.
3. Spring elasticity will not affect the elasticity of material

Disadvantages

Following are the disadvantages

1. Force .vs. displacement curve will form by the system which makes the system slower
2. Will not portable

4.3 DESIGN # 3: FORCE AND SPRING GAUGE WITH SIMPLE MODULE

This is another design in which two gauges have added in the system. One is force gauge and second is spring gauge. In this way the whole system will able to draw the curves of force and displacement at the same time and can monitor both curves live and make the system portable and easy to carry as well. Following is the figure showing the design idea.

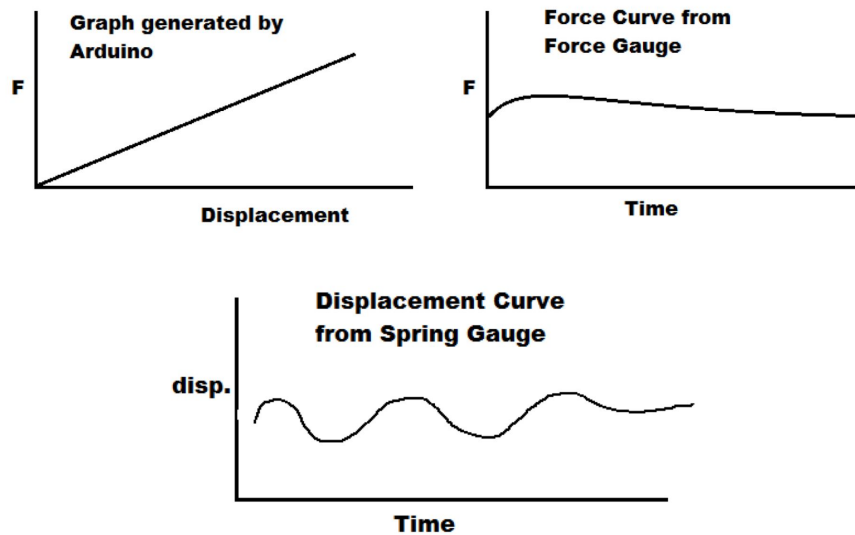
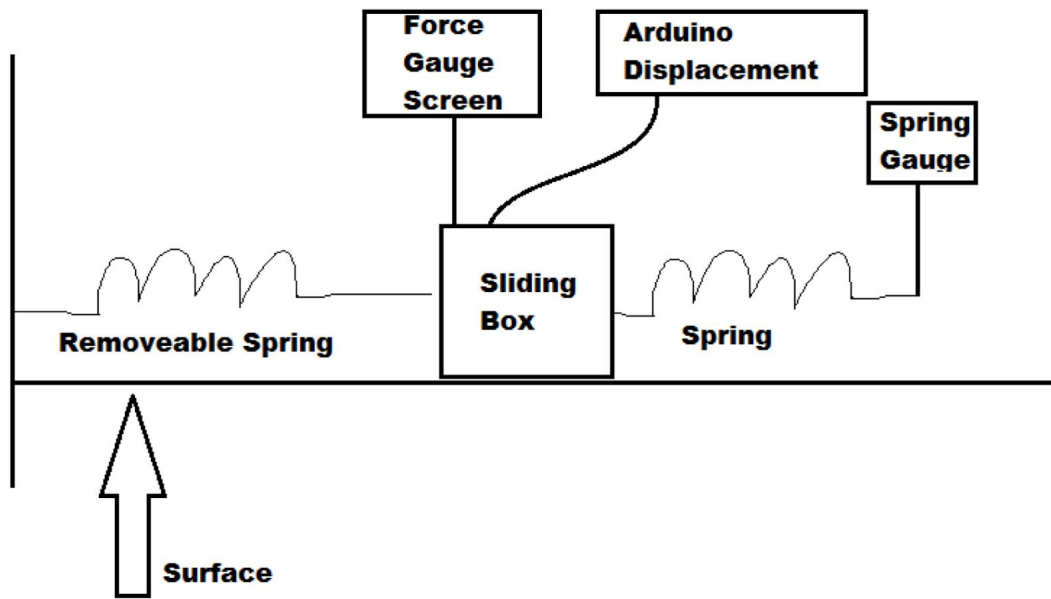

Figure 15: Simple module with force and spring gauge

Advantages

Following are the advantages of this system

1. Displacement and force curves will monitor through the gauges.
2. Easy to understand the material behavior from the live gauge results

3. Removable spring can make it easy to adjust and slide over the surface
4. Spring elasticity will not affect the elasticity of material
5. Portable system

Disadvantages

Following are the disadvantages of system

1. Interlink of force gauge and spring gauge to form the force vs. displacement is difficult.

4.4 DESIGN # 4: BOX SLIDING OVER FRICTIONAL SURFACE

This is another design that we found about frictional force and how it is affecting the system, shown in figure 16 below. Here we will consider the frictional force acting against the applied force by the user, forming a type of resistance. The surface of the system will have a friction coefficient, which will be determined later on, where we will consider the safety of the user when it comes to the roughness of the surface.

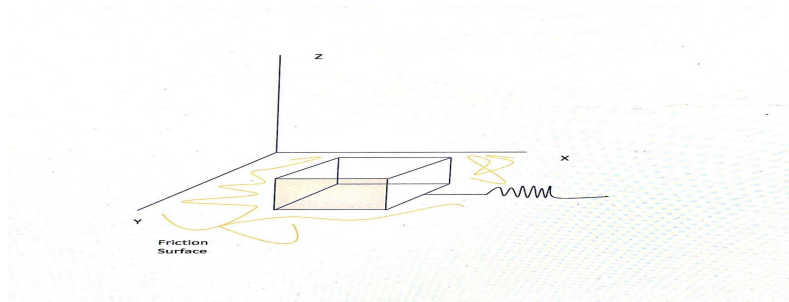

Figure 16: Box sliding over frictional surface.

Advantages

1. Additional resistance.
2. Visualizing how friction act on the given material.
3. Has a more interesting Net Force acting on the box.

Disadvantages

1. The frictional surface can be dangerous to user.
2. User must be careful with using his hand.

4.5 DESIGN # 5: BOX ATTACHED WITH A SPRING ALL CONNECTED TO A RIGID WALL

This design shows how the springs are important to the overall design, as shown in figure 17. Having springs is one of our client's needs, where she specified being able to add/remove springs on demand. Adding another feature to the design, which is being module. It show how we used walls to act as a resistance force, which also makes things more interesting when studying the elasticity of a certain material.

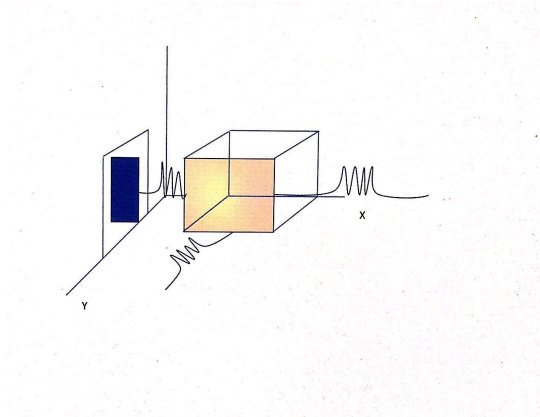

Figure 17: A box with spring connecting to the rigid wall

Advantages

1. Springs are applied in both the x & y directions.
2. Module Built.
3. Adds resistance to the force applied.

Disadvantages

1. Multiple users required to use the system.
2. User must be careful because using springs.

4.6 DESIGN # 6: BOX CONNECTED WITH A SPRING & THE RIGID BODY IS CONNECTED ON THE Z PLANE

This design shows the force how is applied in the z-direction. As shown in figure 18 below, we added another wall that works in the z-direction. This type of force can cause deformation to the box, which satisfies the cause, but also is not required. We can see the box deform as it reaches the elastic state, but will also need to be replaced after a trial.

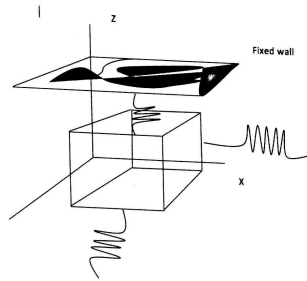

Figure 18: A box connected with a springs along X & Z axis

Advantages

1. Applied force and displacement
2. Friction is applied

Disadvantages

1. Springs are on different sides.
2. 3D design - not required.
3. Different boxes.

5. DESIGN SELECTED

In this section we will talk about the design that we search about. This section include the rationale design selection which focuses on the purpose of the project. The Pugh chart which shows the different types of requirements and what the client is looking for. Also the decision matrix is an important part in this section which have the weight, frictional link and etc. This section will narrow down our options into our final design selected.

5.1 RATIONALE FOR DESIGN SELECTION

Purpose of this project is to understand the elastic behavior of materials after they reached to their elastic limit. For this purpose we are building a product which can read the behavior of system by sliding the material box over the surface. The product will then develop a force vs. displacement curve which will help us in understanding the material characteristics. Therefore few design ideas have presented in the previous section and in this section we are finalizing the design idea and selecting the one which will implement in actual. In order to finalize the design ideas we have used two different techniques first one is Pugh chart and second one is decision matrix.

Pugh Chart

Pugh Chart is a type of chart which determine if the engineering requirements and client requirements are meet. Our design meet with the engineering and client requirements. We came up with 10 different designs that will help us in creating our design. The pugh chart helped us narrow down our options from 11 designs to the best design. The team gave each customer requirement a certain weight and also listed them from most important to the least. The design with four springs in all direction was set to be our datum. The reason behind that, is that we're expecting our client to use at most four springs. We then compared all the other designs to it and visualize how the other designs exceeded the datum or failed to meet our expectations. The design with the highest total is set to be our final design.

10 Designs	Weightage	Simple Basic Module	Force Gauge Screen	Force and Spring Gauge	Sliding Box	One wall attachment	Two wall there springs	Two wall springs	Rollers Sliding Box	Spring pressure sensor	Spring in four directions
Desktop sized	8	+	+	+	-	+	+	-	+	+	Datum
Large to seen in classroom	7	+	+	+	+	+	-	+	+	-	Datum
Small to store in office	6	-	+	+	-	-	-	-	-	+	Datum
User control	5	+	+	+	-	+	+	-	+	-	Datum
Tension and Compression	4	+	+	+	+	+	+	+	+	+	Datum
Direction of force	3	-	+	+	-	-	-	-	-	-	Datum
Tabletop model	2	+	+	+	-	-	+	-	-	+	Datum
Module Built	1	+	-	+	+	-	-	+	-	+	Datum

Number of Plus		6	7	8	3	4	5	3	4	5	Datum
Number of Minus		2	1	0	5	4	-	5	4	3	Deteum

Table 1.2: Pugh Chart

For this project we have selected top two ideas from Pugh chart and these two ideas are:

1. Force Gauge with Simple Module
2. Force and Spring Gauge with Simple Module

Above two design have narrow down from the Pugh chart because both designs have gauge screens which is giving benefit to plot force vs. displacement graph. And design number 3 has portability advantage as well that's why these two designs have narrow down for final result. Next step is to put these results in decision matrix to narrow down the result.

Decision Matrix

In decision matrix, a matrix has formed in which each requirement has assigned a specific value and that value has then multiplied with the number obtained by idea on the basis of its condition according to the requirement and summing up all the numbers for an idea to get the result of each idea and the selected design will be the one which got the highest value in it.

Decision matrix	Desktop sized	Large to seen in class	Small to store in office	User Control	Tension and Compression	Direction of force	Table top Model	Module built	Total
Weightage	8	7	6	5	4	3	2	1	
Force and Spring Gauge	6x8=48	6x7=42	2x6=12	7x5=35	7x4=28	5x3=15	5x2=10	1x1=1	191
Force Gauge	4x8=32	5x7=35	3x6=18	1x5=5	2x4=8	4x3=12	2x2=4	2x1=2	87

Table 1.3: Decision Matrix

From decision matrix we have obtained the final design as

1. Force and Spring Gauge with Simple Module

This design has advantage over the other design in a way that it is using two gauges which is making more easy and portable system. It can plot the force vs. displacement curve easily because to these two gauges and these advantages make this design idea as a final design.

5.2 DESIGN DESCRIPTION

From the decision matrix we have finalized a design Force and Spring Gauge system which is showing below. The springs will be handled by the user. The force gauge is attached to the spring end, in order to pull on it and apply force. The arduino will be inside a frame box which will be attached on the top of the box. The frame will also include displacement sensors on all four corners of the frame. The springs will be module, where the user can attach them to the hooks that are located on both walls and also all faces of the box. The arduino and force gauge is then connected to computer software, which will display the force vs. displacement graphs.

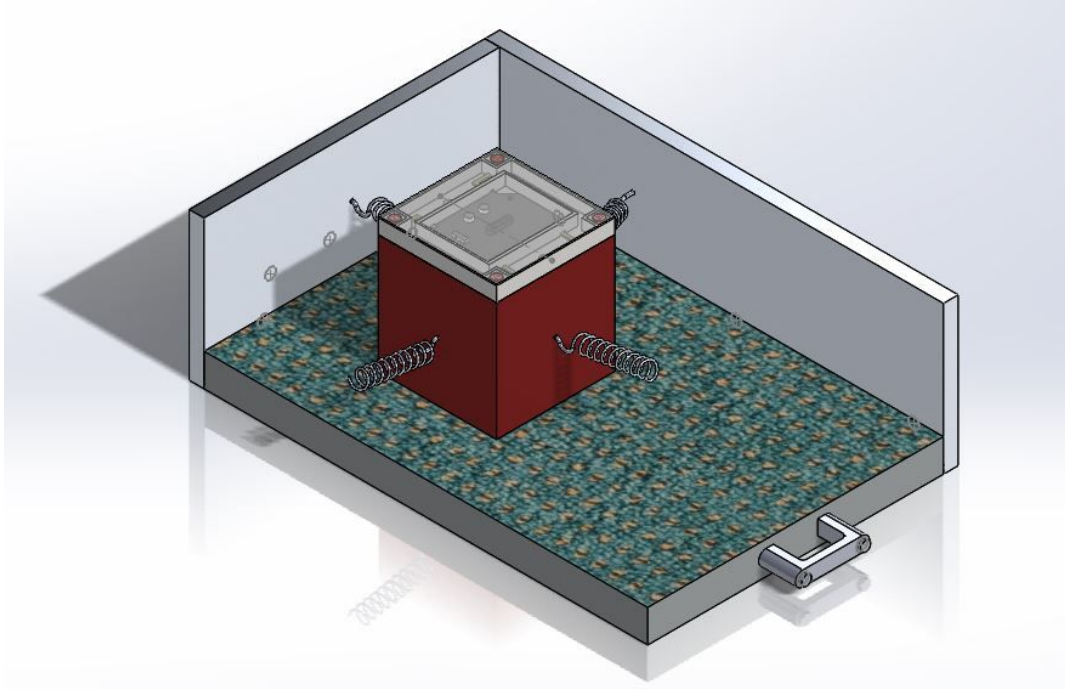

Figure 21: Final CAD Model

The walls and base will be made out of aluminum, which is considered light weight metal. It will help with the durability of the device, but also still easy to carry and move around. The surface of the base will be covered in carpet, which will provide some sort of friction without damaging the box itself. The bottom face of the base will be rubber, that will help hold the device in place when in use. The box will be made out of polyethylene, a type of plastic, as specified by our client.

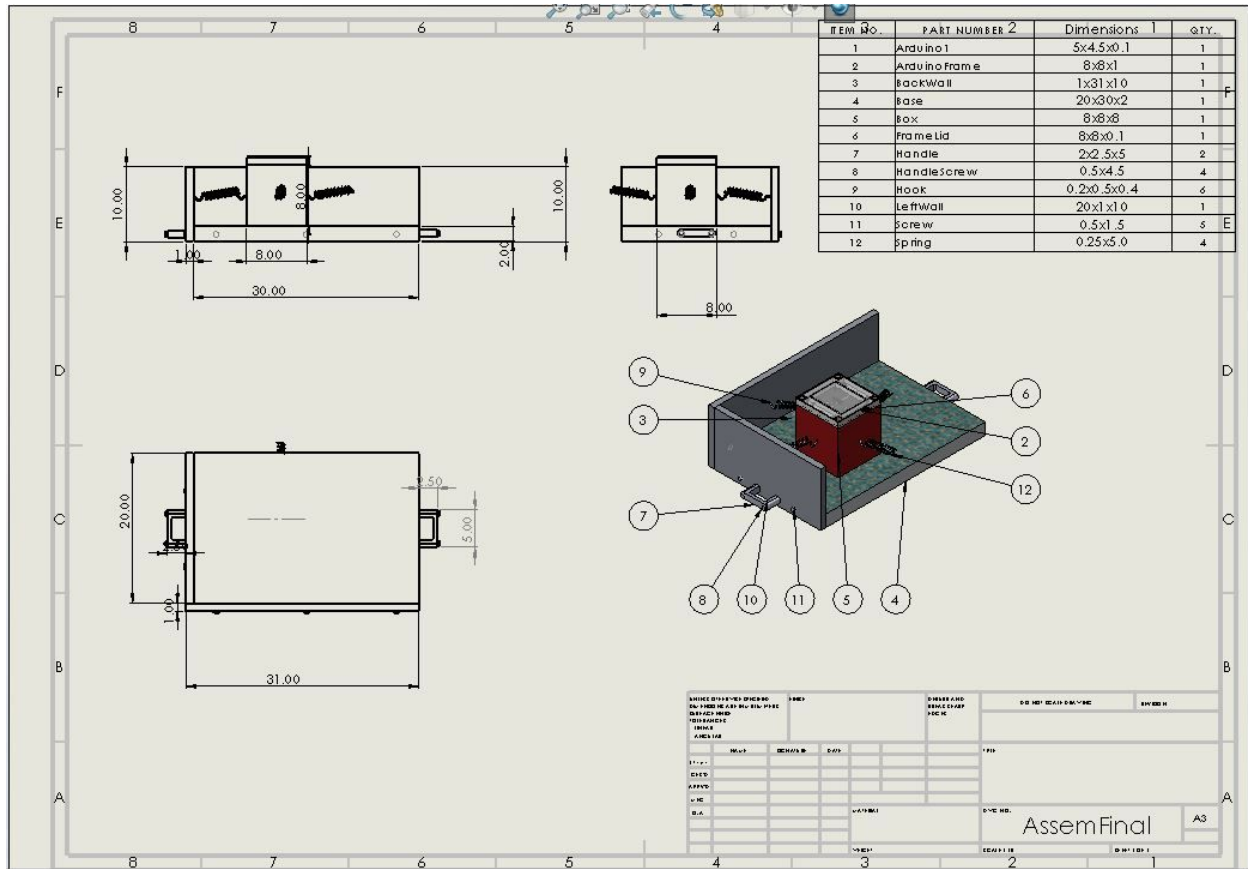

Figure 23:Final drawing with BoM

6 PROPOSED DESIGN

The design selected for this project has presented already and ready to start the building process next semester. Further details of this design can view from the bill of materials and schedule for the future work can view from the Gantt chart. We will use the machine shop to build the frame and we will use hand tools in adding the springs and the carpet. The sources of our design will be bought online and the shipping and tax are including on the cost and budget chart. The Arduino frame will be molded to fit the arduino and it's sensors. The walls and base will have to be manufactured by the machine shop. This CAD model above include our finalized dimensions and materials used. The team is ready to move forward and start building the exoskeleton of the device, which is the walls and base.

6.1 BILL OF MATERIALS

The bill of materials (BOM) is helpful to simplify all the components of the system and its manufacturing process. It also specifies the quantities needed and the function of each part. The

BOM maybe upgraded in the future if the team came up with a slight change in the finalized design. The BOM will be found in Appendix B.

6.2 GANTT CHART

Gantt chart is present in Appendix C. Gantt chart has the complete schedule of what's going in future. It shows all the tasks that the group will need to complete in order for the project to a success. Gantt chart is a good way to track the working. From Gantt chart we can also check if we are behind the schedule or not. So in this way Gantt chart helps in completing the project on time.

6.3 COST AND BUDGET

The budget will be team proposed to our client, where the range is between \$500-\$2000. Since the project total cost is lower than the range anticipated, the team is willing to start ordering the parts needed and hand the clients the receipts. The force gauges cost us almost 70% of our budget. The total cost of parts and shipping will be included in the BOM, as for the manufacturing price of the frame, it will be determined next semester when the team meets with the machine shop.

7. REFERENCES

- [1] "The Nature of Science", *UCAR Center for Science Education*, 2017. [Online]. Available: <https://scied.ucar.edu/teaching-box/nature-science>. [Accessed: 02- Oct- 2017].
- [2] "BMP180 Barometric Pressure Sensor Hookup - learn.sparkfun.com", *Learn.sparkfun.com*, 2017. [Online]. Available: <https://learn.sparkfun.com/tutorials/bmp180-barometric-pressure-sensor-hookup->. [Accessed: 03- Oct- 2017].
- [3] "How to use a Speed Sensor with Arduino", *Brainy-Bits*, 2017. [Online]. Available: <https://brainy-bits.com/blogs/tutorials/speed-sensor-with-arduino>. [Accessed: 03- Oct- 2017].
- [5] Anon, (2017). [online] Available at: <http://R. Hill, Mathematical Theory of Plasticity, Oxford University Press, 1950>. [Accessed 4 Oct. 2017].
- [6] Anon, (2017). [online] Available at: <http://R.I. Tanner, Engineering Rheology, 2nd edition. Oxford University Press, 2000>. [Accessed 4 Oct. 2017].
- [7] Amazon, "Aluminum Sheet", available [online], https://www.amazon.com/RMP-125-3003-Aluminum-Sheet/dp/B00HRHB5XA/ref=sr_1_1?ie=UTF8&qid=1510339684&sr=8-1&keywords=aluminum+sheet
- [8] Amazon, "Box", available [online], https://www.amazon.com/Rubbermaid-Commercial-3508WHI-8-5gal-White/dp/B00063KZQ0/ref=sr_1_6?ie=UTF8&qid=1510339786&sr=8-6&keywords=box+polyethylene
- [9] Amazon, "Springs", available [online], https://www.amazon.com/Swordfish-31070-Extended-Compressed-assortment/dp/B00VBGHJCY/ref=sr_1_3?ie=UTF8&qid=1510339821&sr=8-3&keywords=springs

- [10] Amazon, “Hooks”, available [online], https://www.amazon.com/Stainless-Hangers-Hanging-Kitchen-Bathroom/dp/B01N0DDKL7/ref=sr_1_3?ie=UTF8&qid=1510339861&sr=8-3&keywords=steel+hooks
- [11] Amazon, “Sand Paper”, available [online], https://www.amazon.com/Sandpaper-Furniture-Finishing-Automotive-Polishing/dp/B01LZ6TG05/ref=sr_1_4?ie=UTF8&qid=1510339874&sr=8-4&keywords=sand+paper
- [12] Amazon, “Arduino UNO”, available [online], https://www.amazon.com/Arduino-Uno-R3-Microcontroller-A000066/dp/B008GRTSV6/ref=sr_1_4?ie=UTF8&qid=1510339903&sr=8-4&keywords=arduino+UNO
- [13] Amazon, “Wires”, available [online], https://www.amazon.com/Solderless-Flexible-Breadboard-Jumper-100pcs/dp/B005TZJ0AM/ref=sr_1_sc_1?ie=UTF8&qid=1510339916&sr=8-1-spell&keywords=jumper+wries
- [14] Amazon, “Force Gauge”, available [online], https://www.amazon.com/Nextech-DFS500-Digital-Back-Lit-Enclosures/dp/B0132H92VU/ref=sr_1_7?ie=UTF8&qid=1510339942&sr=8-7&keywords=force+gauge
- [15] Amazon, “Screws”, available [online], https://www.amazon.com/Hillman-591518-Machine-Assortment-195-Pack/dp/B00CR8ZRC4/ref=sr_1_3?ie=UTF8&qid=1510339959&sr=8-3&keywords=screw

8. APPENDICES

8.1: APPENDIX A: HOUSE OF QUALITY

Customer Requirement	Weight	Engineering Requirement	Compat Design	Weight of system	Frictional Factor	Motion/Force sensor	Length of Sliding Area	Wireless Control distance	X & Y Displacement.	Elasticity	Pushing/Pulling Force	Build Box - material?	Spring Expansions	Durability	Reliability	Weight of Sliding Box
1. Easy to be stored in an office	10		9	3				1				9			3	9
2. Visable from a distance	4		1					1		3		9				9
3. Desktop sized	8		9	3								3		3	3	3
4. Various types of spring	1						3	3	3				9			
5. Portable	9		3	9								3			3	3
6. Easy to carry	6		3	9				1				3			1	3
7. Generate different types of graphs	7					9				9	9				9	
8. Module built	3				3		9	9	9	3		1	9	9		1
9. x&y displacment	5					9	9	9	9	3	3		3			
10. Friction surface	2				9									3		
Absolute Technical Imporance (ATI)			211	189	27	108	75	95	75	99	78	198	51	93	150	198
Relative Technical Imporance (RTI)			1	3	12	5	10	7	10	6	9	2	11	8	4	2
Target ER values			25"x25"	40 lbs	any -1	1	1m	5m	1m	3ft	10N	4"x4"	1 ft	2 yrs	max	8 lbs
Tolerances of Ers																
Testing Procedure (TP#)																

8.2 APPENDIX B: BOM

Table 1.6: BOM

8.3 APPENDIX C: GANTT CHART FOR THE SECOND SEMESTER.

